

Rev./ Rev. Tag	Datum/ Date	Ändring/ Rev. number	Inörd av/ Revised by	Kontroll/ Checked	Godk/ Approved
A	2006-01-20	5278	UB	MW,JE	CL
B	2009-01-09	5983	MB	MW	CL
C	2013-02-22	6755	ME	-	CL
D	2016-02-26	7231	MB	-	PS
E	2017-09-07	7444	OE	-	MK

This drawing is property of Z-Lyften Produktion AB and is based subject to return upon demand. It is not to be reproduced or used directly or indirectly in any way detrimental to the interest of Z-Lyften Produktion AB.

Den här ritning är Z-Lyften egendom och skyddas enligt internationella gällande lag för copyright och får ej utan Z-Lyften skriftliga medgivande kopieras, delas eller obehörigen användas.

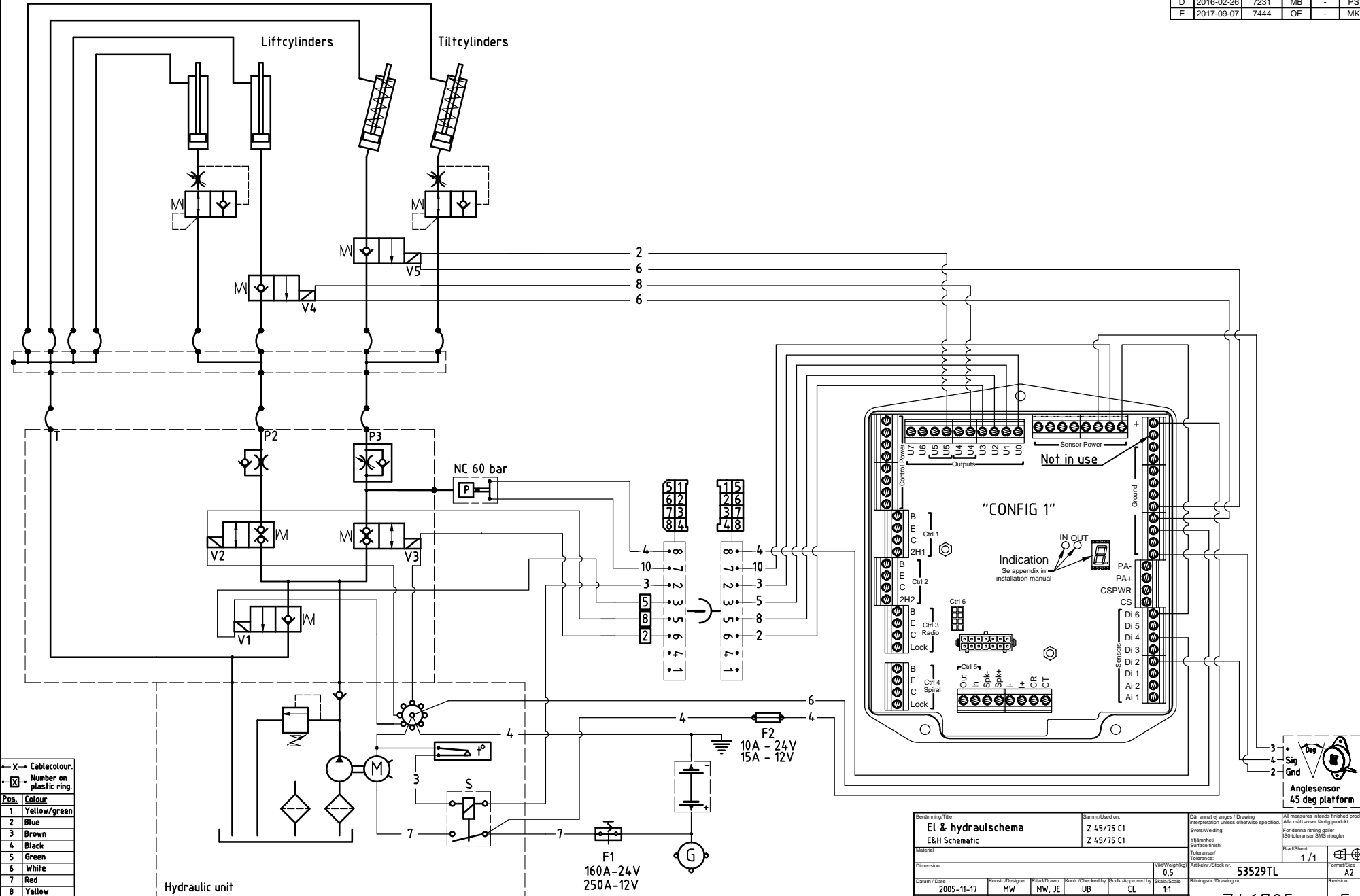

Pos.	Colour
1	Yellow/green
2	Blue
3	Brown
4	Black
5	Green
6	White
7	Red
8	Yellow
9	Grey
10	Orange

- X - Cablecolour
- [X] - Number on plastic ring.

Benämning/Title El & hydraulschema EKH Schematic		Samt./Used on: Z 45/75 C1 Z 45/75 C1		Där avsnitt ej anges / Drawing interpretation unless otherwise specified.		Alla mått avser färdigt produkt. For dimensions refer to finished product.	
Material		Skala/Scale 0.5		Antal/Sheet 1/1		Form/Size A2	
Datum / Date 2005-11-17		Konstr./Designer MW		Ritad/Drawn MW, JE		Kontroll/Checked by UB	
ZEPRO		Z-Lyften Produktion AB		53529TL		Z46785	
						Revision E	