

ZEPRO Z 15-150

Loading diagram

(170 bar)		12 volt	24 volt
Pump - Motor Unit		220 A	120 A
Lowering valve		1,4 A	0,7 A
Shift valve		3,8 A	2,0 A
Magnet (electric safety valve)		1,5 A	0,75 A
Solenoid		1,8 A	0,9 A
Cable areas:	Control cable	1,5 mm ²	1,5 mm ²
	Main cable 0-8 m	35 mm ²	35 mm ²
	Main cable 8-15 m	35 mm ²	35 mm ²
	Main cable >15 m	-	35 mm ²
Power source:	Min. capacity	180 Ah	170 Ah
	Min. voltage	9 volt	18 volt

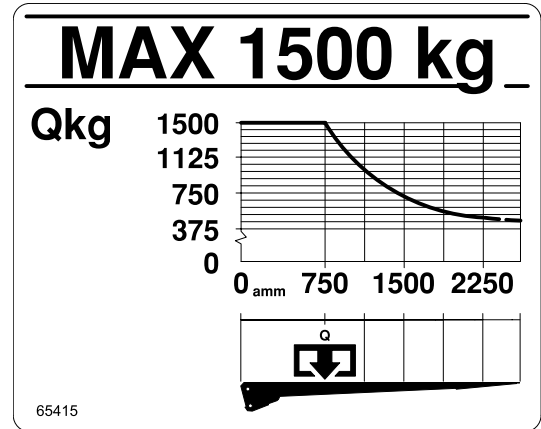

Installation dimensions (mm)

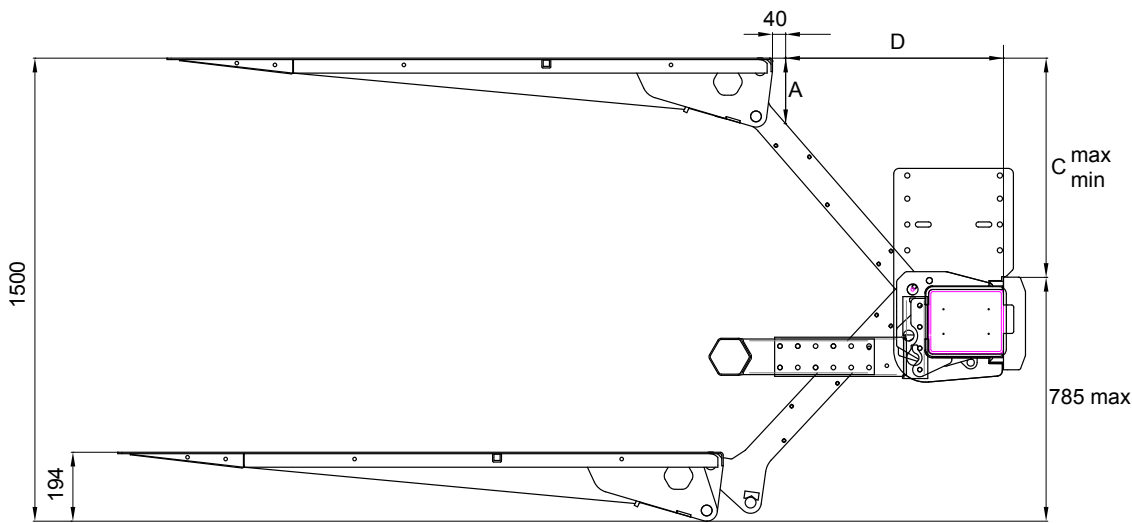

C	A	D
715	192	674
650	163	757
600	150	809
550	138	853
500	128	891
450	119	924
400	112	952
350	105	976
325	102	987

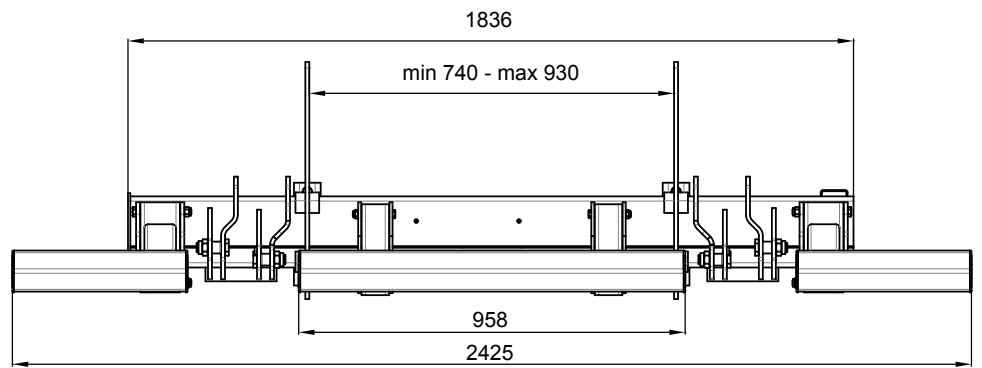
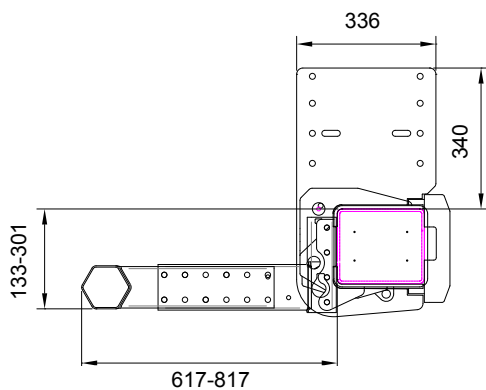

2014-04-14

ZEPRO Sales

Tel.: +46 (0)150 489 550
 Fax: +46 (0)150 489 551, +46 (0)150 489 566
 E-mail: zepro@zepro.com | zepro.com

