

ZEPRO Z 100-110

(200 bar)		12 volt	24 volt
Pump – Motor Unit		200 A	90 A
Magnet (hydraulic unit)		1,5 A	0,75 A
Magnet (electric safety valve)		1,5 A	0,75 A
Solenoid		1,8 A	0,9 A
Cable area	Control cable	1,5 mm ²	1,5 mm ²
	Main cable 0-8 m	35 mm ²	35 mm ²
	Main cable 8-15 m	50 mm ²	35 mm ²
	Main cable >15 m	-	35 mm ²
Power source	Min. capacity	140 Ah	110 Ah
	Min. voltage	9 volt	18 volt

Loading diagram

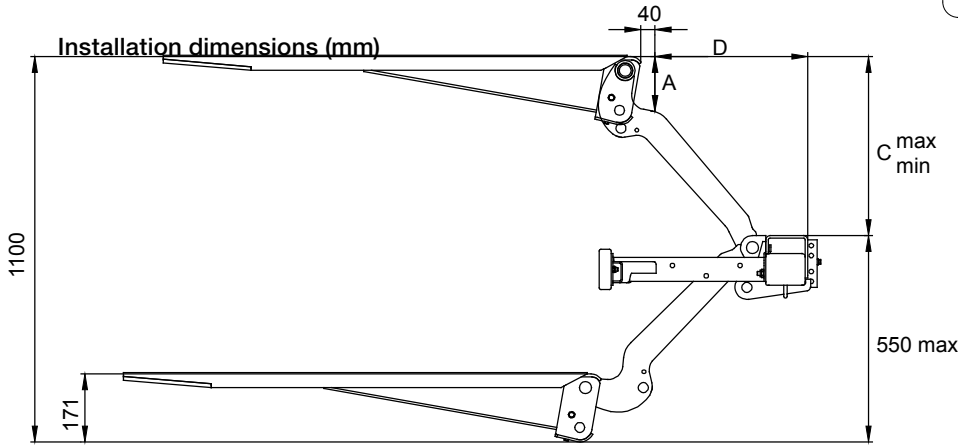
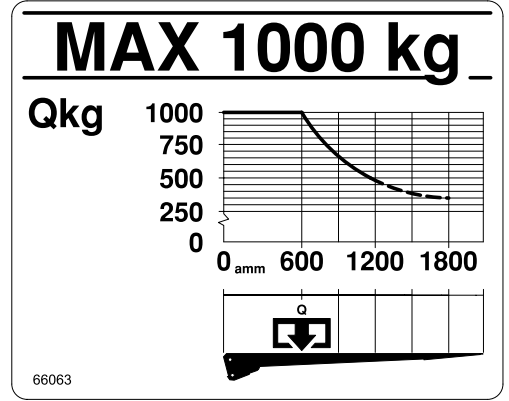

C	A	D
550	147	449
500	133	510
450	123	559
400	115	598
350	109	631
300	103	657

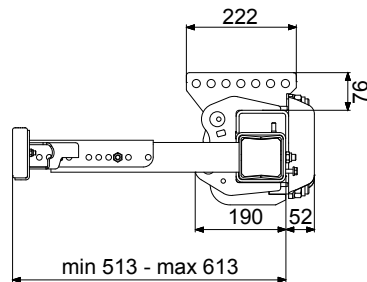
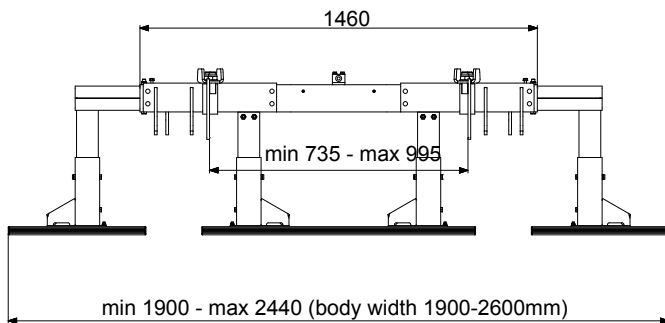
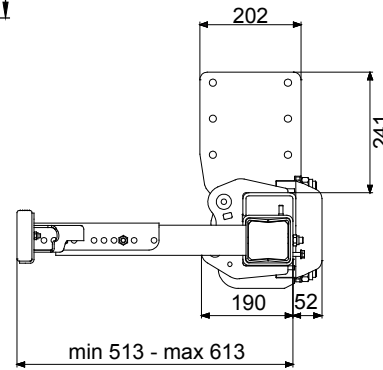
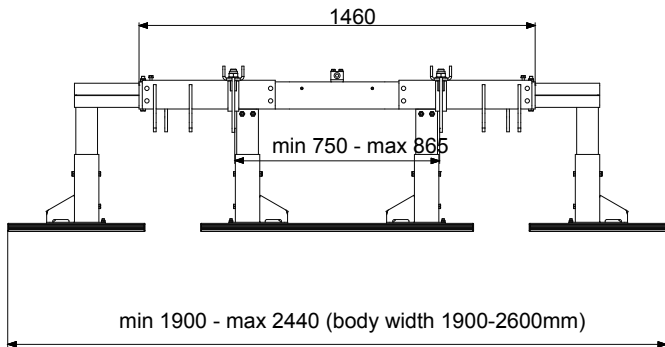

2017-05-02

ZEPRO Sales

Tel.: +46 (0)150 489 550

Fax: +46 (0)150 489 551, +46 (0)150 489 566

E-mail: zepro@zepro.com | zepro.com

