

ECE TYPE-APPROVAL CERTIFICATE



Communication concerning²

Approval granted
~~Approval extended~~
~~Approval refused~~
~~Approval withdrawn~~
~~Production definitively discontinued~~

of a type of mechanical coupling device or component pursuant to Regulation No.55.

Approval No: **E24*55R01/07*0490*00**

Reason for extension:

-N/A

1. Trade name or mark of the device or component: **ZEPRO**
2. Manufacturer's name for the type of device or component: **Z75D17**
Non-standard drawbeam
3. Manufacturer's name and address: **Z-LYFTEN Produktion AB**
64149 Katrineholm
Sweden
4. If applicable, name and address of the manufacturers representative: **N/A**
5. Alternative supplier's names or trade marks applied to the device or component: **N/A**
6. Name and address of the company or body taking responsibility for the conformity of production: **Z-LYFTEN Produktion AB**
64149 Katrineholm
Sweden
7. Submitted for approval on: **26.02.2019**
8. Technical service responsible for conducting approval tests: **TÜV SÜD Auto Service GmbH,**
Westendstraße 199,
D-80686 München,
Germany
9. Brief description
- 9.1 Type and class of device or component: **Type: Z75D17**
Class: F

² Strike out what does not apply.

Approval No: E24*55R01/07*0490*00

9.2 Characteristic values

9.2.1 Primary values:

D: **17.2 kN**
Dc: --
S: **160 kg**
U: --
V: --

Alternative values:

D: --
Dc: --
S: --
U: --
V: --

9.3 For Class A mechanical coupling devices or components, including towing brackets:

Vehicle manufacturer's maximum permissible vehicle mass: *N/A*

Distribution of maximum permissible vehicle mass between the axles: *N/A*

Vehicle manufacturer's maximum permissible towable trailer mass: *N/A*

Vehicle manufacturer's maximum permissible static mass on coupling ball: *N/A*

Maximum mass of vehicle, with bodywork, in running order, including coolant, oils, fuel, tools and spare wheel (if supplied)but not including driver: *N/A*

Loading condition under which the tow ball height of a mechanical coupling device fitted to category M1 vehicles is to be measured – see paragraph 2 of annex 7, appendix 1: *N/A*

9.4 For class B coupling heads, is the coupling head intended to be fitted to an unbraked O1 trailer: ~~yes/no~~² *N/A*

10. Instructions for the attachment of the coupling device or component type to the vehicle and photographs or drawings of the mounting points given by the manufacturer: *See manufacturer's documentation*

11. Information on the fitting of any special reinforcing brackets or plates or spacing components necessary for the attachment of the coupling device or component: *See manufacturer's documentation*

Approval No: **E24*55R01/07*0490*00**

- | | | |
|-----|---|--|
| 12. | Additional information where the use of coupling device or component is restricted to special types of vehicles - see annex 5, paragraph 3.4: | <i>See manufacturer's documentation</i> |
| 13. | For Class K hook type couplings, details of the drawbar eyes suitable for use with the particular hook type: | <i>N/A</i> |
| 14. | Date of test report: | <i>18.02.2019</i> |
| 15. | Number of test report: | <i>18-00194-CX-GBM</i> |
| 16. | Approval mark position: | <i>Type plate on draw-beam arm left or right side, adhesive</i> |
| 17. | Reason(s) for extension of approval: | <i>N/A</i> |
| 18. | Approval granted/ extended/refused/withdrawn : | <i>Granted</i> |
| 19: | Place: | <i>Dublin</i> |
| 20. | Date: | <i>02nd April, 2019</i> |
| 21. | Signature:  |  |
| 22. | The list of documents deposited with the Administration Service which has granted approval is annexed to this communication and may be obtained on request. | |

Index to the Information Package

Date of issue:	<i>02nd April, 2019</i>
Date of latest amendment:	<i>N/A</i>
Reason for extension/revision:	<i>N/A</i>
1. Additional conditions, and advisory notes on legal alternatives.	
2. Test report(s)	
- numbers(s):	<i>18-00194-CX-GBM</i>
- date of issue:	<i>18.02.2019</i>
- date of latest amendment:	<i>N/A</i>
3. Information document	
- number(s):	<i>Z75D17</i>
- date of issue:	<i>06.02.2019</i>
- date of latest amendment:	<i>N/A</i>
Documentation:	<i>167 pages</i>

Approval No: E24*55R01/07*0490*00

Appendix: **Additional conditions, and advisory notes on legal alternatives**

A: Additional conditions:

1. The attached technical report, with any of its attachments, forms part of this Type Approval certificate.
2. Each type from series production shall be to the measurements specified in the attached drawings, and shall be manufactured only from the materials specified in the Approval documents.
3. Changes in the type are permitted only with the explicit permission of NSAI. Breaches of this requirement will lead to a withdrawal of the Type Approval, and in addition may be subject to criminal prosecution.
4. At regular intervals, any tests or associated checks prescribed by the applicable legislation to verify continued conformity with the approved type shall be carried out. The manufacturer shall demonstrate compliance with this by submitting to NSAI evidence of adequate arrangements and documented control plans for each type approved.
5. Any set of samples or test pieces showing evidence of non-conformity shall give rise to further sampling and testing and all steps shall be taken to restore conformity of production.
6. This Type Approval will expire when it is surrendered by the holder, or withdrawn by NSAI, or when the approved type no longer conforms to legal requirements. The recall of the Type Approval can be issued by NSAI when the conditions required for the issuing or continuation of the Type Approval are no longer current, or when the Approval holder is in breach of the duties attached to the Type Approval, or when it is established that the approved type no longer meets the requirements of traffic safety.
7. Changes in the company name, address or manufacturing site, as well as in any of the sales or other agents specified in the issuing of the approval must immediately be notified to NSAI.
8. The duties imposed by the issuing of this certificate are not transferable. The legal protection of third parties is not affected by this certificate.
9. When the manufacture or sale of the system, component or separate technical unit has not been started within one year of the date of issue of this certificate, then NSAI is to be informed. This requirement also applies when the manufacture or sale has been halted for more than one year, or when it ought to have been halted for more than one year. The initial commencement of manufacture or sale, or the resumption of manufacture or sale, shall then be notified to NSAI within one month of commencement or resumption.

B: Legal Options:

Any objection to the requirements set out in this certificate shall be made within one month of the date of issue. The objection shall be made, in writing, to NSAI in Dublin.

Zepro Acronym system ZL75/Z75/ZN75 for EEC Component Type Approval of Mechanical Coupling Devices for Motor Vehicles and their Trailers (regulation UNECE R55.01)

Z75D17*###

dated 2018/05/03

Truck Mounting Bracket Sets

Drawing Number	Acronym/ Code = ###
Z46890	FD1
Z47566	IV1
Z47008	TY1
Z47381	MB1
Z47345	MB2
Z46887	FD2
Z47220	VWMB1
Z47216	VWMB2
Z52279	FD3
Z54321	VW1
Z54323	

Truck Mounting Brackets may be fitted to any of the Frame support assemblies including Tow Bar assembly

Frame Support including Tow Bars

Name	Acronym/ Code = *
ZL75	L

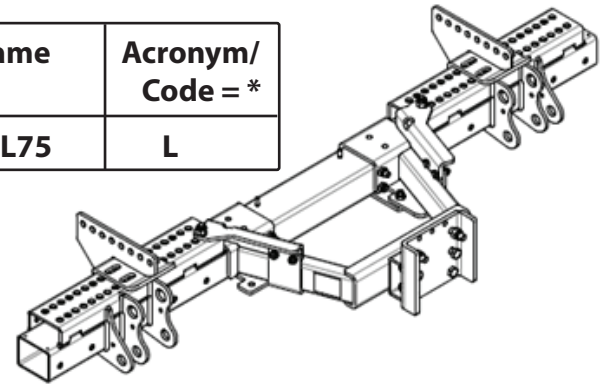

Name	Acronym/ Code = *
Z75	S

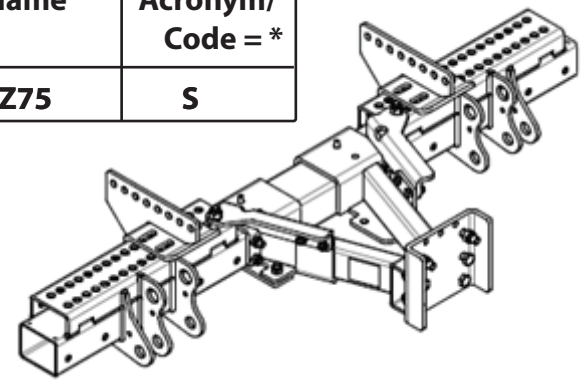

Name	Acronym/ Code = *
ZN75	N

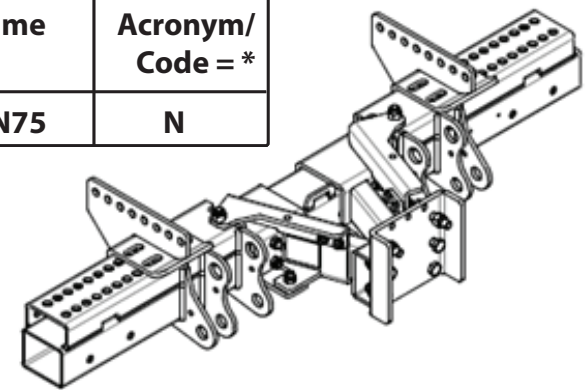

Frame Support Drawing Number

Tow Bar Derivatives Drawing Number

Z46712

Fits

- Z47145
- Z47146
- Z51628
- Z47391
- Z47404

Frame Support Drawing Number

Tow Bar Derivatives Drawing Number

Z46725

Fits

- Z47394
- Z47405
- Z47144
- Z47143

Frame Support Drawing Number

Tow Bar Derivatives Drawing Number

Z46726

Fits

- Z47142
- Z47141
- Z47395
- Z47406

Mounting Brackets Z46731 with brackets 58990TL is fitted to all three models.